



Fiddler's Rag

Vol. 44, Number 8
Celebrating 43 years

Santa Clara Valley Fiddlers Association
www.scvfa.org or www.fiddlers.org

August 2016
Next Jam: Aug 7



President's Note

August 7th SCVFA Jam in the Municipal Rose Garden Park.

The July 4th weekend jam in the idyllic setting of the Rose Garden Park was near perfect. With over 60 attendees, a handful of listeners and at least six varying jam circles, an exciting afternoon was had by all. It was good to see our past president and treasurer, Richard Brooks and Janet Johnston, who made the trek down from El Cerrito to jam with us.

We were also visited by a Parks Department Representative, who was very pleased with SCVFA and loved the music. She stressed the importance of following park rules. **No dogs, no littering, no alcohol. Only service dogs are permitted.**

August 7th in the Municipal Rose Garden Park at the intersection of Naglee Ave. and Garden Drive.
Jam times: 1:00 - 5:00pm **Come early... 11:30 to reserve our location near Garden Drive.**
Slow Jam: 1:30 - 2:30 led by Topher Heath
Tune Builders: 2:00 - 3:00 led by Dave Barton
Remember to bring a chair.

Thank you Pete Showman for managing the July jam.

Thank you Topher Heath for always being there to lead the popular Slow Jam.

SCVFA now has a Facebook Page. Look for: Santa Clara Valley Fiddlers Association SCVFA. Share it with your friends and invite new friends to get to know our music community. Posts are encouraged, but please limit the content to that which is directly related to SCVFA. All posts will be moderated in keeping with the best interests of SCVFA.

The Good Old Fashioned Bluegrass Festival is just around the corner. SCVFA will have a promotional

table at the event. Let your friends know that Santa Clara Valley Fiddlers Association is there. Several volunteers and I will be taking shifts at the table. Any additional volunteers to sit a short shift will be appreciated. See you all there.

Many of you may have heard the KKUP Radio interview of me and Elan Alford. We are both proud to represent SCVFA and carry on the leadership roles where so many before us have, and continue to invest their energies. The radio spot was a great way to put SCVFA in the spotlight and to spread public awareness of our organization. It is also important that each one of our members talks about SCVFA and shares our enthusiasm with fellow musicians, family, and friends.

Take a few business cards and share them when the opportunity presents itself.

It takes a village to keep SCVFA running smoothly.
Let's all do our part,

--- Susan Goodis

Some of the many ways to get involved:

Board meeting - all SCVFA members are welcome -
For date and location, ask any Board member.

Amazon purchases – go to Amazon from the SCVFA home page to give a small commission to SCVFA.

Come and jam with us every month.

In This Issue:	Page
President's Message	1
SCVFA Happenings.....	3
Photos from the July Jam by Paul Barnett	4
Fiddle Tunes 2016 by Dorian Martinka and David Barton	5
American Dance and Music Week by Lee Anne Welch	5
Celtic Traditional Music by Liz Alsop and Patti Bossert	6
Tune: June Apple	7

The Fiddler's Rag is published monthly by the Santa Clara Valley Fiddlers Association and is provided to members of the Association. The Santa Clara Valley Fiddlers Association (SCVFA), founded in 1973 in San Jose, California, is a nonprofit, volunteer-operated organization dedicated to the preservation, teaching, and enjoyment of traditional music. The first membership in a household includes the Fiddler's Rag; additional members sharing the newsletter are steeply discounted. To join, sign up at the jam or see www.fiddlers.org/join.

Officers and Chairs

President-Trustee	Susan Goodis	Newsletter Publisher ..	Charlotte Prater
Vice President	Élan Alford	Performances Contact ..	Dave Williams
Recording Secretary	Anne Raphael	Publicity	OPEN
Treasurer	Dinah Showman	Webmaster	Pete Showman
Membership Secretary	Pete Showman	Youth Programs Chair	OPEN
News Editor	Patrice Tanti		

Trustees

Seat 1: Pete Showman	Seat 3: Bert Raphael	Seat 5: Dave Williams
Seat 2: Élan Alford	Seat 4: Wes Mitchell	Seat 6: OPEN

To Contact the SCVFA:

Mail: P.O. Box 2666, Cupertino, CA 95015-2666
 Email to Susan Goodis: [president \[at\] fiddlers.org](mailto:president@fiddlers.org)
Newsletter Submissions & Comments: [newsletter \[at\] fiddlers.org](mailto:newsletter@fiddlers.org)
Address changes: [membership \[at\] fiddlers.org](mailto:membership@fiddlers.org)
 Website: www.scvfa.org or www.fiddlers.org
 Copyright 2016, Santa Clara Valley Fiddlers Association

KAMIMOTO
 STRING INSTRUMENTS

**“Fiddles
 for
 Every Style...”**

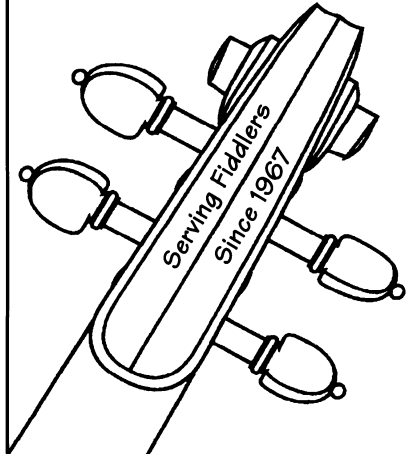

- New & Old Instruments
- Repairs & Restorations
- One-hour bow rehairing (by appt.)
- Rentals: Violin, Viola, Cello, Bass

Hours: Mon-Sat 10:00 - 5:30

[408] 298-8168
www.kamimotostrings.com

609 North Fourth Street
 San Jose, CA 95112

[800] 892-3199

Fax: [408] 298-8198

From Marin to Monterey, Tracy to Tiburon...
 ...we're in the heart of bluegrass country



THE NORTHERN CALIFORNIA
 BLUEGRASS SOCIETY
 www.ncbs.us

Since 1982 the Northern California Bluegrass Society has promoted bluegrass and old time music in the San Francisco Bay and Monterey Bay areas. This highly active club has nurtured the development of bands and venues. The NCBS hosts the Good Old Fashioned Bluegrass Festival each August, an event that solely features California bands. We sponsor festivals, concerts and jams all over the area. Members receive the Bluegrass By the Bay magazine each quarter. Please join us!

SCVFA Happenings

Keep SCVFA healthy; offer assistance 1-2 times a year to transport sound equipment from the storage locker.

SCVFA Slow Jam

Thank you all for participating in the slow jam. The slow jam is for beginners who want to participate in a slow-paced jam (60-90 BPM). To participate, you should be able to tune your instrument, play chords at a steady pace, and (optionally) work up melodies / leads. We keep things at an easy pace and we often play breaks together (old time style) even on non-fiddle tunes. This makes it possible for you to join the jam where ever you are at in your development as a musician. So, come join us!

All the tunes we have played so far are fair game even if they are not on the active list. We can revisit tunes especially at the end when we have gone through the active list.

The active song list is:

Angeline The Baker (D)
Arkansas Traveler (D)
Girl I Left Behind Me (G)
Jaybird (D)
June Apple (A Mixolydian) NEW SEE PAGE 7
Liberty (D)
Mississippi Sawyer (D)
Over The Waterfall (D)
Red-Haired Boy (A)
Red Wing (G)
Soldier's Joy (D)
Squirrel Hunters (A Mixolydian)
St. Anne's Reel (D) NEW
Swallowtail Jig (E Dorian) NEW
Whiskey Before Breakfast (D) NEW
Wildwood Flower (C)

Check here first for songs:

www.scvfa.org/tunes/

If you have trouble finding a song, feel free to contact me for ideas.

Note: To add or remove yourself from the email list for the Slow Jam, send a request to topher.heath [at] yahoo.com.

Topher Heath

KidFiddle Workshop and Mini-Concert

Sunday October 2nd, 2016

Instructor/Performer: Elizabeth Dequine

KidFiddle Workshop: 2:00-3:00 PM

- **Tuition is only \$5**
- **Youth admission to the jam is free**
- KidFiddle workshops are intended for advanced-beginner to intermediate fiddlers, 17 and under.
- You can sign up at the event, but we'd appreciate hearing from you in advance ([kidfiddle /at/ fiddlers.org](http://kidfiddle/at/fiddlers.org)) if you know a young fiddler who would like to participate.
- After the workshop, we'll invite the students to play what they have learned on stage and then join others in a **Youth Jam**. (Students are also welcome to participate in our regular **Slow Jam** before the workshop, starting at 1:30).

Mini-concert starting at 3:30 PM

- After the workshop, Elizabeth will perform a short concert.

Youth Jam after mini concert

Young musicians are invited to play together in a Youth Jam led by SCVFA trustee Wes Mitchell, whether or not they attended the workshop.

23rd Annual NCBS 2016 Good Old Fashioned Bluegrass Festival

www.scbs.org/2016/04/11/ncbs-good-old-fashioned-bluegrass-festival-official-flyer/

Tres Pinos, CA August 11-14

16th Annual Redwood Dulcimer Day 2016

www.communitymusicschool.org/dulcimer_day

Scotts Valley, CA August 20

Ramona Bluegrass & Old West Fest

www.ramonabluegrassfest.com

Ramona, CA August 28th

July Jam Photos

By Paul Barnett



Photographers ... or wanna be's - share your talent by photographing memorable times at SCVFA events - send to Pat Tanti at newsletter [at] fiddlers.org

This week we are featuring Paul Barnett's keen eye for capturing genuine jam passion.

Paul is a long time SCVFA member and Tune Builder leader. Thanks Paul for leading again with memorable shots.



“Fiddle Tunes” 2016

By Dorian Martinka and David Barton

Several Bay Area residents traveled to Port Townsend, WA, to attend the 40th annual Festival of American Fiddle Tunes - always in 4th-of-July week.

We enjoyed great instructors, including: Frank Ferrell, Frank Maloy, Jimmy Triplett, Pete Sutherland, Rafe Stephanini and Bertram Levy (Old-Time), Wendy MacIsaac and Katie McNally (Cape Breton), Tony DeMarco (Irish), Alicia Svigals (Klezmer), the Savoy Family (Cajun), Paul Anastasio (swing fiddle), Laurie Lewis and Tom Rozum (bluegrass), a Brazilian-music group, and a Michoacan, Mexico group. There were classes for banjo, accordion, guitar, mandolin, piano, choral singing, too, and classes for attendees’ small children.

Fiddle Tunes always takes place at beautiful Fort Worden, where “Officer and a Gentleman” was filmed. Classes, “band labs,” tutoring sessions, and most jams happen inside buildings (in case of inclement weather). Instructors lodge on “officer’s row.” After dances and hosted jam sessions, parties at these houses often enliven the night.

Many participants stay in campus dorms. Campers choose between two state park areas (in the woods or on the beach), or at the nearby county fairgrounds, some in the “Mule Barn” area, where non-participants can stay just to jam. (Yes, at FT you risk burning both ends of your candle!)

During “FT week,” guest artists perform world-class public concerts in “The Pavilion,” a re-purposed WWII blimp hanger. Our favorite performers this year included Alicia Svigals’ klezmer concert (her last time back at Fiddle Tunes was 20 years ago) and Grupo Apui from western Brazil.

In town you see many signs of community participation. Although weather was cool this year, Fiddle Tunes proved remarkably joyful, and surely a life changing event. If you award stars for Music Camps, you’ll surely give FT all five!

American Dance and Music Week

By Lee Anne Welch

I would recommend the American Dance and Music Week to anyone who is interested in fiddling and/or contra dance and is also able to walk up and down hills. I was able to attend this local five day camp which took place at the Jones Gulch YMCA camp in La Honda. It took place the last week of June and was sponsored by BACDS (Bay Area Country Dance Society).

Some people chose to bring their own tents but I decided to stay in a small cabin with several of my musician friends. Each day started off with breakfast at 8am and before breakfast was a fabulous (optional) event. Musicians would gather to greet the day by playing waltzes, and dancers would waltz. I would go back and forth between playing and dancing. Then we would all sit down for breakfast. What a great way to start the day!

In the mornings I took two fiddle classes with Rodney Miller and Pascal Gemme. Rodney is the New England style fiddler who plays with the Stingrays (Max Newman, Stuart Kenney, David Surette, Matt Kenney) and Pascal is the Quebecois fiddler with Genticorum (Yann Falquet, Nicholas Williams). In each class we learned several tunes, worked on bowing and discussed playing in bands and for dances. It was quite an opportunity to work with these master fiddlers for five days.

More ways to get involved:

Play on stage for the SCVFA open mic.

Pass on performance inquiries to Dave Williams at performances [at] fiddlers.org

Be a leader - Teach a tune at the monthly Tune Builder Circle.

Celtic Traditional Music Here We come!

By Liz Alsop and Patti Bossert

On Father's Day week-end, a few Celtic music-loving fiddle friends (Liz and John Alsop, Patti Bossert, Cindy Dinga and Susan Goodis) decided to try something different (and closer!) than the Grass Valley Bluegrass Festival. They wandered off into the redwoods near Boulder Creek and Big Basin to check out the Sempervirens Trad Music Weekend and found other SCVFA and Celtic-music friends attracted to the same.

This was the first camp for adults hosted by the Community Music School (CMS) of Santa Cruz. The school is a nonprofit organization founded in 1993 by recording artist/music teacher Shelley Phillips. In addition to providing "living history" concerts to the public and many other events, the school hosts two Celtic music camps for children and teens each summer. Teachers specializing in Celtic music and instruments staff these camps. As the teens have grown up, they have become talented musicians and have become the teachers and TAs for the next generation of children/teen camps. After hearing requests for years, CMS decided to have their first adult music camp this year.

It was a long weekend (Thursday evening through Sunday afternoon) of workshops, jam sessions, singing and dancing. The teachers were Molly's Revenge members David Brewer (winds and percussion), John Weed (fiddle and cello) and Stuart

Mason (guitar and mandola), as well as Jesse Autumn (harps and keyboards), Shelley Phillips (bamboo flute making, folk-singing and shape note choir), Janet Herman (Irish tenor banjo/mandolin and lap dulcimer), Michael King (English country dance), and many more.

Most classes were held outside under the redwood trees for shade and to enjoy the beautiful countryside around us. In the daytime there were workshops and in the evenings, various activities such as a concert, English country dance, a talent show, and sessions. Susan was excited to hear and play music that is often played at the local Contra Dances.

Cindy felt that the camp demonstrated the importance of community. "It is there in the Scottish as well, but there is also the element of competitive individualism from the Vikings ancestry. From the Irish sessions, I got the importance of the whole community...and not just the star players...everyone is important, like a whole breathing being together as one while playing. I never experienced anything like that, especially as an orchestra musician."

Quote from Patti Bossert: "There was something mystical about playing Celtic music with my Irish grandfather's fiddle under the venerable redwood groves and feeling part of an ancient tradition of playing tunes 'old as the hills' together, mentored by a tight-knit community passionate about the traditions from which my grandfather came."

We look forward to next year's Sempervirens Trad Music Weekend and hope more will join us.



Celtic music-loving fiddle friends at the Sempervirens Trad Music Weekend
(Photo by Susan Goodis)

Key: A Mixolydian
 ♩ = 90

June Apple

Traditional, arr. Pete Showman

This is about how I usually play it, though I sometimes simplify it a time or two if I get tired of playing (or hearing) so many notes. For example you could start the A part like this, leaving out some of the "fill" notes:

You can find lots of other variations; for example,

the Fiddler's Fakebook and the Phillips Collection both do measure 2 like this:

and the Fiddler's Fakebook starts the B part like this (another example of a less-notey variation):

Arr. and typeset in ABC Plus by Pete Showman 7/4/2016.

Santa Clara Valley Fiddlers Association
P.O. Box 2666
Cupertino, CA 95015-2666

Rose Garden Park August 2016

**Next Jam: Sunday Aug 7th at 1 pm
Rose Garden Park (see map)
Look for us under the trees!**

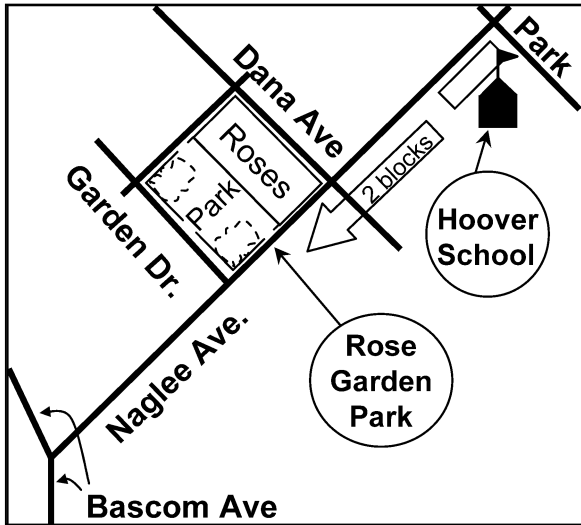

Damaged or Missing Issue? Call us,
or email to: newsletter [at] scvfa.org

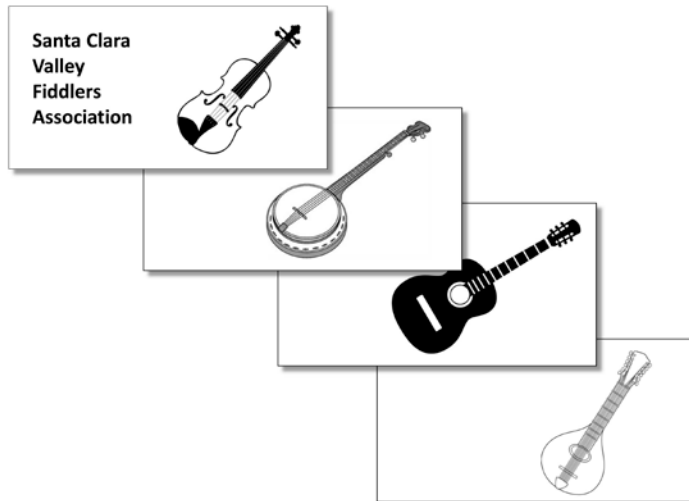

Keep SCVFA healthy; Take a few SCVFA business cards to hand out to fellow musicians.