



# Fiddler's Rag

Vol. 44, Number 2  
Celebrating 42 years

Santa Clara Valley Fiddlers Association  
[www.scvfa.org](http://www.scvfa.org) or [www.fiddlers.org](http://www.fiddlers.org)

February 2016  
Next Jam: Feb. 7



## President's Note

It is **very important** for members to attend our February jam. We will hold our annual membership meeting and need a quorum to elect or reelect two trustees. I will also report on the state of the association. The new Board of Trustees will appoint a new President. Allow extra time for driving on Super Bowl weekend.

This is my last month as President. It's been almost 8 years since I took over from Paul Clarke in April 2008. Paul followed Pete Showman in February 2007, and Pete became President in June 2001.

In March, we start our 44<sup>th</sup> year! The SCVFA is doing very well thanks to the dedication of our members, our Board, our officers, and our newsletter editor Pat Tanti. We are an all-volunteer public-benefit 501(c)(3) non-profit organization.

### Happy 100th Birthday Svend!

On February 28, Danish jazz violinist Svend Asmussen, my very favorite musician, will be 100 years old. Read about this fascinating musician in the Selected Articles Archive link in our website's Newsletter section.

### Happy-New-Year Discount Continues through March

The door admission is \$5 for everyone through March thanks to the generosity of our Board of Trustees. Invite a friend and save \$3 off the \$8 non-member rate.

### Help at the Storage Locker (1 mile from the jam)

Volunteer to help take our storage locker supplies to the jam. Fifteen minutes to load and ten minutes to drive.

### New 1:30 PM Start Time for the Slow Jam

Starting in February, the Slow Jam group will start at 1:30 PM and end around 2:30 PM.

### Amazon Buyers

On the lower left side of our [www.fiddlers.org](http://www.fiddlers.org) website we have a link to Amazon. If you click on it to go to Amazon, we get a small commission if you make a purchase. It costs you nothing and it really helps us.

- Richard Brooks

## KidFiddle Workshop

Hoover Middle School

Sunday March 6<sup>th</sup>, 2016

With Fiddle instructor and performer:

**Erik Hoffman**



Jam 1-5pm

**Erik's Mini-concert 3:30**

New Year Discount: Adult Admission \$5.00  
Free Admission for Youths 17 and under

**KidFiddle Workshop 2:00 - 3:00**

For youths 17 and under \$5.00 Tuition

Sign up at KidFiddle /at/ Fiddlers.org  
Open Mic before and after the concert  
More details & general SCVFA information  
[www.Fiddlers.org](http://www.Fiddlers.org)  
or call Susan Goodis at 650-336-5561

## In This Issue:

## Page

President's Message .....	1
KidFiddle workshop .....	1
SCVFA Happenings .....	3
Article: Thankful for a Banjo in Baltimore by Élan Alford .....	4, 5
Article: "The Story Behind the Tune" by Patrice Tanti.....	6
Tune: Mary's Wedding .....	7
SCVFA Rag Calendar .....	8

The Fiddler's Rag is published monthly by the Santa Clara Valley Fiddlers Association and is provided to members of the Association. The Santa Clara Valley Fiddlers Association (SCVFA), founded in 1973 in San Jose, California, is a nonprofit, volunteer-operated organization dedicated to the preservation, teaching, and enjoyment of traditional music. The first membership in a household includes the Fiddler's Rag; additional members sharing the newsletter are steeply discounted. To join, sign up at the jam or see [www.fiddlers.org/join](http://www.fiddlers.org/join).

**Officers and Chairs**

President-Trustee ...	Richard J. Brooks	Newsletter Publisher ..	Charlotte Prater
Vice President .....	OPEN	Performances Contact ..	Dave Williams
Recording Secretary	Dinah Showman	Publicity .....	OPEN
Treasurer .....	Janet Johnston	Webmaster .....	Pete Showman
Membership Secretary	Pete Showman	Youth Programs Chair .....	OPEN
News Editor .....	Patrice Tanti	Youth Fiddle Contest ..	Pete Showman

**Trustees**

Seat 1: Pete Showman	Seat 3: George Bradshaw	Seat 5: Dave Williams
Seat 2: Élan Alford	Seat 4: Charlotte Prater	Seat 6: Susan Goodis

**To Contact the SCVFA:**

Mail: P.O. Box 2666, Cupertino, CA 95015-2666  
 Email to Richard Brooks: [president /at/ fiddlers.org](mailto:president@fiddlers.org)

**Newsletter Submissions & Comments:**

Email: [newsletter /at/ fiddlers.org](mailto:newsletter@fiddlers.org)

Website: [www.scvfa.org](http://www.scvfa.org) or [www.fiddlers.org](http://www.fiddlers.org)  
 Copyright 2016, Santa Clara Valley Fiddlers Association

**KAMIMOTO**  
 STRING INSTRUMENTS

**“Fiddles  
 for  
 Every Style...”**

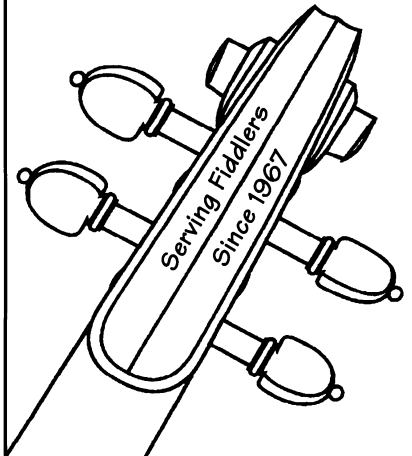

- New & Old Instruments
- Repairs & Restorations
- One-hour bow rehairing (by appt.)
- Rentals: Violin, Viola, Cello, Bass

Hours: Mon-Sat 10:00 - 5:30

**[408] 298-8168**  
[www.kamimotostrings.com](http://www.kamimotostrings.com)

609 North Fourth Street  
 San Jose, CA 95112

**[800] 892-3199**

**Fax: [408] 298-8198**



**Glenn Raphael**, son of SCVFA member Bert Raphael, open mic during the January jam. Glenn's performance included one of his compositions *Gorilla My Dream*. The song was inspired by a trip to see the rare black mountain gorillas in Rwanda (Sabyinyo group). This song was featured on the KPCC Pasadena radio station show Dr. Demento.  
 (Photo: Susan Goodis)

## SCVFA Happenings

### Annual Meeting & Trustee Election

Reminder: the SCVFA annual member meeting and election will be held beginning at 3 pm during the February jam. Anyone is welcome to attend, but only SCVFA members in good standing (i.e., dues paid up) may vote.

We will elect two trustees to three-year terms. There are two nominees: **Bert Raphael** (for seat 3), and **Wes Mitchell** (for seat 4). See the January issue of the Fiddler's Rag for the candidates' statements.

We will then vote to ratify (or reject) the proposed bylaws changes. See the January issue of the Fiddler's Rag for the changes to the SCVFA bylaws.

After that the outgoing president Richard Brooks will give us an update on the state of the association, and provide an opportunity for questions and suggestions.

### Members, Check Your Listings

Have you changed your email address or phone number, and forgotten to tell us? Want to list both home and cell phones? Now's your chance to give us those updates.

The Board has authorized printing an updated **Member Directory** booklet. At the February jam, please stop by the Membership Desk to check your listing and make any corrections. If you can't get to the February jam, email updates to membership /at/ fiddlers.org.



### KidFiddle Workshop in March

We are planning a *KidFiddle* workshop for the **March jam**. The instructor will be **Erik Hoffman**. See the SCVFA website's Events page for details: [fiddlers.org/events](http://fiddlers.org/events).



### SCVFA Slow Jam - Now at 1:30 instead of 2:00

The slow jam is for beginners who want to participate in a slow-paced jam (60-90 BPM).

Song List for February 2016:

Fiddler's Rag February 2016

D Angeline The Baker; D Arkansas Traveler; G Girl I Left Behind Me; G Hot Corn, Cold Corn; D Jaybird D Liberty; G Long Journey Home; D Mississippi Sawyer; G Mountain Dew; D Over The Waterfall; A Red-Haired Boy; D Soldier's Joy; C Wildwood Flower; A Will The Circle Be Unbroken; G Worried Man Blues.

## SCVFA Meeting Notes

**At its regular meeting on November 15, 2015,** trustees

- Voted to update signers on the SCVFA bank account to add Dave Williams and to remove Paul Clarke, who is no longer a trustee.
- Authorized reimbursement to Susan Goodis for SCVFA-logo tote bags purchased for use by members.
- Reviewed proposed bylaws changes; the details of the proposed changes noted in the next three bullets were included in the January 2016 newsletter and will be voted on in the February 7 association meeting. Trustees voted to adopt changes to:
  - Article V Section G (3) regarding authorized signers on the SCVFA bank account.
  - Article IV Section B (3) increasing the advance time needed for receipt of names of candidates nominated by petition in order for their names to appear in the meeting notice.
  - Article III Sections B, C and D regarding membership applications and due dates.

**At its regular meeting on January 24, 2016,** trustees

- Agreed to hold the July and August jams in the Rose Garden Park. Decision to be made later about September.
- Voted to authorize printing of a member directory. Members are encouraged to review their information in the draft at the back table at the February jam for accuracy before we print it.
- Agreed to raise the amount we charge for playing for other groups. These "payouts" help raise funds for SCVFA.
- Thanked Richard Brooks and Janet Johnston for their long service as SCVFA president and treasurer, and thanked Charlotte Prater and George Bradshaw, who are leaving the board, for serving as trustees.
- Set March 20, 2016 as the proposed date for the next regular trustee meeting.

*Dinah Showman, Secretary*

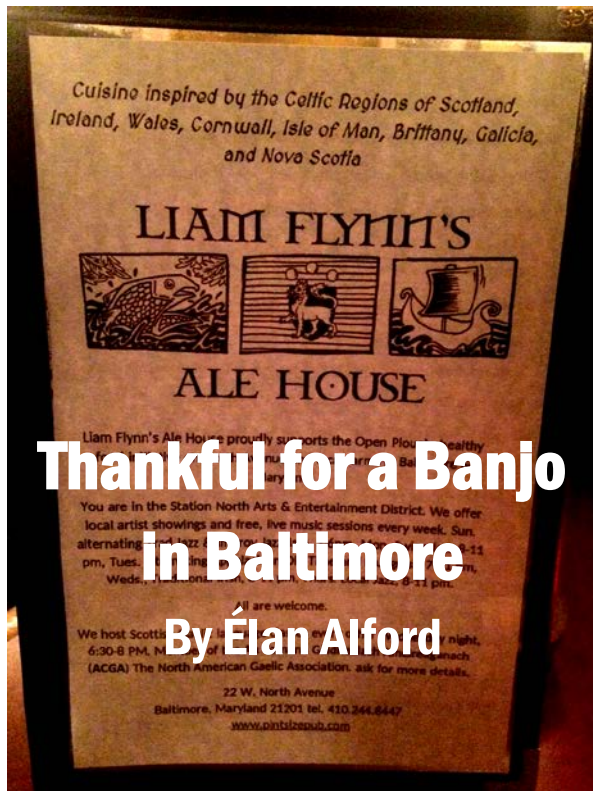

## Thankful for a Banjo in Baltimore By Elan Alford

I have a travel banjo stashed way up in the closet of a room at my parents' retirement home in Delaware. One visit, sometime soon, I will have to take it out and play at the Delaware Bay or Atlantic Ocean. However, on my recent trip home for the 2015 Thanksgiving holiday, I took that little banjo to Baltimore, Maryland to attend a jam.

I was seeking the Baltimore Old-Time Jam, which is held on alternating Tuesday nights each month at Liam Flynn's Ale House 222 W. North Avenue (note 1). The place has a Celtic menu and an outstanding selection of locally crafted beers, ciders and meads.

I arrive an hour before the jam is scheduled to start and order a veggie pot pie and a basil lemongrass mead from Charm City Meadworks. After I order at the bar I sit down upstairs to wait for dinner to come. It arrives quickly and is enjoyed thoroughly.

I found out about this jam from a Google search. All I knew was that there is a slow session at 7:00 and it switches to a fast jam around an hour later. The fast jam goes until 10:30 or later, if people want to keep playing. As I sit eating my dinner, I see people slowly trickle in with instruments. I look around and see that the bar has high flat ceilings, so I wonder what the sound quality will be like. I finish my dinner and order a cranberry IPA from Flying Dog. By this

time a circle is forming in the center of the downstairs table area.

As I join the circle with my travel banjo, I notice that calling it a circle doesn't quite do it justice. Everyone is pulled in real close, much more in the southern way. As we get engrossed in playing, it really becomes more a mish-mash of instruments and arms pulsing like rhythmic gears and pegs. Ken Kolodner and his son Brad Kolodner (note 2) started this Baltimore jam a few years ago. Both are professional musicians and as teachers they wanted to have a place where their students could go out and play. Now they still run the jam and it is a place where people will come just to listen in also. Observers sit at the outskirts of the circle, at the bar, or at the tables and sometimes applaud or sometimes just watch and chat. The scene here is firstly an operating bar. The large cadre of musicians crowd into the center and bring that vibrating air of coalescing energy churning in the middle of an evening bar crowd rush.

That night they start in the key of G and a din of tuning begins. The banjos plunk into tune. A G chord here and there, then off we go, starting with *Seneca Square Dance*. It starts out rather so slowly because it is the slow jam. You can hear the extra ornaments that the advanced players know. You can hear the strong bones of the melody laid out by Ken Kolodner's fiddle. Brad Kolodner picks out a fine banjo part and the B section of the tune really shines. My banjo was made from a kit and has a nice big flower that I painted in the center. The flower makes me smile and the banjo has a light and airy tinkling sound.

Slowly the Seneca tune morphs into a faster version. Around and around it continues to go. By the end of the tune, the notes have started to strut around the room in a big, giant swirl. Music rolls off the walls and the bar. It mixes with the voices of the bystanders. It carouses with the foot tapping rhythm. The room has an ethereal quality as the sound rises and floats to the ceiling. Up it goes and drifts away. I start to wonder how beginner players learn in a place like this. The acoustics make me feel disoriented and like I am in a dream because of the high ceiling. Sound is difficult to interpret; it is like a round with measures blending into each other as vibrations bound around the hall.

Nonetheless the next tune is called *Shove That Pig's Foot Further into the Fire*. This one and *Seneca Square Dance* are two of my favorite tunes that I learned by ear when I started attending the local

Fandango Monday night jam in 2012 or so. Needless to say, I am having a blast already, two songs in, no matter what the room's acoustics do. There are lots of banjos and fiddles. There are guitars and mandolins. Even a hammered dulcimer player is present.

Now we launch into a third tune, *Nail that Catfish to a Tree*. After three songs (and 25 minutes) we come to tune that I don't really know, *Possum on a Rail*, in G. The B part goes high and it has rollicking and rolling feel to it. By the end of this tune I notice that a bass and player have finally shown up! Next Ken starts *Josie-O* and then *The Blackest Crow*. Following this we switch to the key of D after having been in G for 45 minutes. After five D tunes (*Spotted Pony*, *Angeline the Baker*, *Cumberland Gap*, *New Five Cents*, and *Fly Around My Pretty Little Miss*), the jam switches to fast mode. Staying in D, we continue with *Home with the Girls in the Morning*, *Run Down Boot*, *Mississippi Sawyer*, *Five Miles from Town*, *Rockingham Cindy*, *Rocky Mountain Goat/Straw Bonnet*, *Cutting at the Point*, *Sarah Armstrong*, another Bayard Collection tune that I missed the name of, *Hell Among the Stallions*, *Indian Ate a Woodchuck*, and *Julianne Johnson*.

The session wraps up after a long stint in A. We played *I'll Fly Away*, *Tipping Back the Corn*, *Gray Haired Dancing Girl*, *Road to Malvern*, *Old Time Fire in the Mountain*, *Black Jack Grove*, *Jeff Sturgeon*, *Chinquapin Hunting*, *Red Prairie Dawn*, another tune I missed the name of, *Snake Hunt/Cliff house*, *June Apple*, *Ruben's Train*, *Breaking Up Christmas*, *Hog Eyed Man*, *Dull Chisel*, *Rattle Trap*, and an original composition *Dog Jump the Fence*.



The recording I made from that evening is four hours and fifteen minutes long! The sound isn't great in the bar because the room is so open and airy with high ceilings and flat surfaces everywhere. Regardless, I had a great time and I got lost in the music. A trip to Baltimore reinforced for me that old time music is where it is at. It feels like home.

I notice that the jam at this bar seems to have a larger presence of younger musicians than what we have at

local south bay jams I attend. I think it is partly a result of Brad Kolodner being an organizer. His band mates from Charm City Junction also attend the jam and sit in for songs (note 3).

When I get asked to call a tune I was sitting across from Brad on fiddle and Anna Roberts-Gevalt (from Anna & Elizabeth (note 4)) on her beautiful sounding arch top Martin. I call *June Apple* and start it out. Brad picks up the lead on fiddle. After the tune ends Anna says that she liked the sound of my banjo. That is quite a compliment for this little kit instrument (note 5).

Soon after the June Apple tune things began to wind down. Anna stops playing and instead dances a few steps. Later others disband too.

It is some time after 11:00 when I head back to Delaware with a smile. The bar is still open but the musicians have all trickled out. The next time I am in the area on a Tuesday night, you'll find me there if the night is right.

If you make it to Baltimore on the right Tuesday, be sure to check it out.

- (1) [pintsizepub.com](http://pintsizepub.com)
- (2) [kenandbrad.com](http://kenandbrad.com)
- (3) [charmcityjunction.com](http://charmcityjunction.com)
- (4) [annaandelizabeth.com](http://annaandelizabeth.com)
- (5) [backyardmusic.com/Banjos.html](http://backyardmusic.com/Banjos.html)

---

**Élan Alford** is a Trustee on the current SCVFA Board. She plays banjo and is learning fiddle. As a Pennsylvania native, she takes pride in being from a state known for friendliness. She is a member and regular jam attendee since late 2012.



## The Story Behind the Tune

By Patrice Tanti – SCVFA Editor

*Mary's Wedding* is the title of a tune Dave Barton taught a small group of "Tune Builder" attendees at the January 2016 jam ("Tune Builder" is a tune-learning group for intermediate-level players led by experienced musicians during the monthly jam). As I joined the line of fiddlers facing Dave, I first assumed this was an old time classic (literally) until Dave handed over the sheet music where one could read: *Commemorating the October 2, 1999 wedding of Mary Larsen and Jerry Holland, 1999 by Dave Barton.*

Dave took the time to share the story behind the tune:

*Soon after Mary announced her and Jerry's wedding plans, I thought of buying them a gift. But the idea of composing a nice new tune for them seemed much better; it quickly pushed all other ideas aside.*

*Composing tunes usually takes time (trying and rejecting various melody ideas, chord progressions, etc.) But Mary's Wedding almost instantly popped into my head, and it seemed right just as it came to me, and I knew I'd soon forget it if I didn't document it right away. So I dropped everything else, opened my music program, Finale, and set to work.*

*Finding the best chord progressions took a little longer, but the melody suggested most of the chords, so that part wasn't difficult, either.*

*Jerry played it for her over the telephone, before she left her home in Los Altos to fly to him [in Canada].*

Sadly Jerry passed away in 2009.

Soon after the jam, I contacted Mary who kindly shared some memories:

*I was honored and delighted when Dave Barton presented me with this great tune he had written on the occasion of my wedding to Cape Breton fiddler/composer Jerry Holland in 1999. Jerry and I got acquainted during a couple of Fiddler Magazine projects (the*

*video "Carrying on the Traditions: Cape Breton Scottish Fiddling Today") and a Fiddler Magazine interview. In Cape Breton style, our wedding included a bagpiper welcoming guests to the church and fiddling during the ceremony. The reception at our home was my first experience with a "house party," with fiddlers, guitarists, and piano accompanists playing into the wee hours.*

This tune, first a wedding gift, continues to connect people years later in unexpected ways. As always, my editing instinct tells me all of you SCVFA members have such songs in your lives.

Tell us about it at [newsletter /at/ fiddlers.org](mailto:newsletter@fiddlers.org).



Jerry Holland (Photo: Carol Kennedy)

---

**Dave Barton** is an SCVFA member and regular jam attendee since 1994.

**Mary Larsen** is the editor and publisher of Fiddler Magazine since 1994. She is also an SCVFA member since 1990. She was our newsletter editor twice, first in the mid-90s and again for a few months in 2012 and 2013.

**Jerry Holland** (1955-2009) is known as one of Cape Breton's finest fiddlers and composers; he recorded many CDs, published two books of his tunes ("Jerry Holland's Collection of Fiddle Tunes" and "Jerry Holland: The Second Collection"), and performed and taught extensively in the U.S., Europe, and Mexico. His career took off while he was still a teenager, performing with the "Cape Breton Symphony" on the weekly TV series The John Allan Cameron Show.

# Mary's Wedding

Commemorating the October 2, 1999 wedding of Mary Larsen and Jerry Holland

1999 by David M. Barton

vln

1 8 14 21 28

G C Em C Em Am7

D D7 G C Em C

G D7 G N.C. G Bm7 Em

G A F#m7 Bm D7 G Bm7

Em G A7 D7 G D7

*Fine*

rev. 1/6/2016

Santa Clara Valley Fiddlers Association  
P.O. Box 2666  
Cupertino, CA 95015-2666

**Next Jam and Annual Membership Meeting: Sunday Feb. 7<sup>th</sup>, 1-5 pm at Hoover Middle School**

For those affected by **Super Bowl** traffic, allow some extra travel time to and from the jam.

SCVFA Jam on the first Sunday of each month.  
Location: Hoover Middle School, 1635 Park Ave., San Jose. The school is at the corner of Naglee and Park. Cafeteria parking is on the Naglee side.

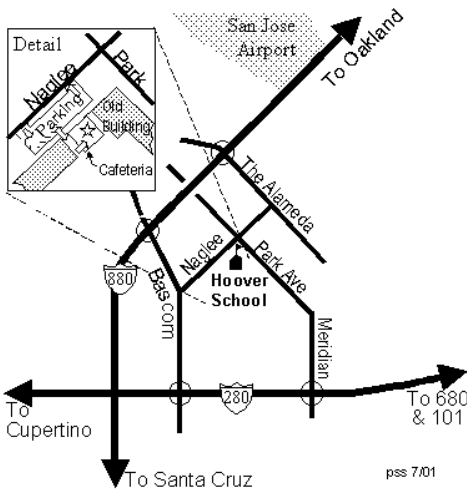

SCVFA Board members at the January 2016 meeting, Richard Brooks' last trustee meeting as dedicated president (Photo: Wes Mitchell).

**2016 RAG CALENDAR**

Article due date



January 2016							February 2016							March 2016							April 2016						
Sun	Mon	Tue	Wed	Thu	Fri	Sat	Sun	Mon	Tue	Wed	Thu	Fri	Sat	Sun	Mon	Tue	Wed	Thu	Fri	Sat	Sun	Mon	Tue	Wed	Thu	Fri	Sat
★3	4	5	6	7	8	9	★7	8	9	10	11	12	13	★6	7	8	9	10	11	12	★3	4	5	6	7	8	9
10	11	12	13	14	15	16	14	15	16	17	18	19	20	13	14	15	16	17	18	19	10	11	12	13	14	15	16
17	18	19	20	21	22	23	21	22	23	24	25	26	27	20	21	22	23	24	25	26	17	18	19	20	21	22	23
24	25	26	27	28	29	30	28	29						27	28	29	30	31			24	25	26	27	28	29	30
31																											
May 2016							June 2016							July 2016							August 2016						
Sun	Mon	Tue	Wed	Thu	Fri	Sat	Sun	Mon	Tue	Wed	Thu	Fri	Sat	Sun	Mon	Tue	Wed	Thu	Fri	Sat	Sun	Mon	Tue	Wed	Thu	Fri	Sat
★1	2	3	4	5	6	7	★5	6	7	8	9	10	11	★3	4	5	6	7	8	9	★7	8	9	10	11	12	13
8	9	10	11	12	13	14	12	13	14	15	16	17	18	10	11	12	13	14	15	16	14	15	16	17	18	19	20
15	16	17	18	19	20	21	19	20	21	22	23	24	25	17	18	19	20	21	22	23	21	22	23	24	25	26	27
22	23	24	25	26	27	28	26	27	28	29	30			24	25	26	27	28	29	30	28	29	30	31			
29	30	31												31													
September 2016							October 2016							November 2016							December 2016						
Sun	Mon	Tue	Wed	Thu	Fri	Sat	Sun	Mon	Tue	Wed	Thu	Fri	Sat	Sun	Mon	Tue	Wed	Thu	Fri	Sat	Sun	Mon	Tue	Wed	Thu	Fri	Sat
★4	5	6	7	8	9	10	★2	3	4	5	6	7	8	★6	7	8	9	10	11	12	★4	5	6	7	8	9	10
11	12	13	14	15	16	17	9	10	11	12	13	14	15	13	14	15	16	17	18	19	11	12	13	14	15	16	17
18	19	20	21	22	23	24	16	17	18	19	20	21	22	20	21	22	23	24	25	26	18	19	20	21	22	23	24
25	26	27	28	29	30		23	24	25	26	27	28	29	27	28	29	30				25	26	27	28	29	30	31
							30	31																			

The stars are the SCVFA monthly Jam dates. The squares are monthly deadlines for submissions of articles, pictures, happenings, etc.