



Fiddler's Rag

Vol. 43, Number 8
Celebrating 42 years

Santa Clara Valley Fiddlers Association
www.scvfa.org or www.fiddlers.org

August 2015
Next Jam: Aug. 2

President's Note



Our July 5 jam in the San Jose Rose Garden Park was a huge success. I was having such a great time that I forgot to take photos.

Our summer park jams are a favorite of many members. It's also a chance for the neighbors to drop by, see us in action, and learn about who we are and what we do. We've gotten new members who live nearby and just came by to enjoy the park.

The Rose Garden Park is under the jurisdiction of the San Jose Parks and Recreation Department. They are supportive of our mission and approved of our having our jam in the park because among other things, our music is all acoustic, we clean up after ourselves, and because we are non-commercial and don't sell anything.

Our jams in the park are also important because they help us accomplish our mission as a community-benefit all-volunteer non-profit organization. To maintain our non-profit status, a few federal and state forms must be filed every year by a July 15 deadline. That ensures any donations are tax deductible.

August 2 at the Rose Garden Park (FREE)

Our August 2 jam will be in the beautiful San Jose Rose Garden Park just down the street from the Hoover Middle School on Naglee. It is FREE because we do not pay to rent the park.

September 6 at the Hoover Middle School

On September 6, we will return to our regular venue at the Hoover Middle School.

Share Your Photos

Share your photos and we will include your name if they are used in the Rag. Email them to newsletter editor Pat Tanti at [newsletter \[at\] fiddlers.org](mailto:newsletter@fiddlers.org).

Amazon Buyers

On the lower left side of our www.fiddlers.org website we have a link to Amazon. If you click on it to go to Amazon, we get a small commission if you make a purchase. It costs you nothing and it really helps us.

- Richard Brooks

Violins at a Fiddle Contest

By Allan French, adapted from his column in the CBA "Bluegrass Breakdown" in May 2015

One reason for the popularity of the violin/fiddle is its extreme versatility. It can render an amazing variety of sounds; it is used by practitioners of widely-differing styles of music and has been popular for several hundred years. Although I have my hands full with the mountain dulcimer and the banjo, I can't help thinking how rewarding it must be to operate such a versatile instrument. In San Jose, I regularly attend SCVFA jams (www.fiddlers.org), so I don't need to learn to play the instrument myself in order to hear it.

The "California State Old Time Fiddlers Association" (www.csotfa.org) has 14 districts. I know that District Six is a very active one, located in the northern part of the state. The SCVFA website has links to several other fiddle associations, including ones located in San Francisco and Oregon.

Guitarist and longtime CBA member, Nancy Zuniga, posted this on the CBA message board on March 15:

"My late friend David Schneider, who played violin with the San Francisco Symphony for 50 years, decided to try his luck in an old time fiddling contest some years ago. This lifelong professional musician took 7th place out of seven contestants in the senior division. After the competition, one of the judges told him, 'You sound like you're a really good violinist!'"

In This Issue:	Page
President's Message	1
Violins at a Fiddle Contest by Allan French	1
SCVFA Happenings	3
SCVFA Worldwide.....	4
Fiddling in Ireland by Ethan Dickson	5
Tune: Cripple Creek	6
Tune: The Girl I Left Behind Me, Liberty	7

The Fiddler's Rag is published monthly by the Santa Clara Valley Fiddlers Association and is provided to members of the Association. The Santa Clara Valley Fiddlers Association (SCVFA), founded in 1973 in San Jose, California, is a nonprofit, volunteer-operated organization dedicated to the preservation, teaching, and enjoyment of traditional music. The first membership in a household includes the Fiddler's Rag; additional members sharing the newsletter are steeply discounted. To join, sign up at the jam or see www.fiddlers.org/join.

Officers and Chairs

President-Trustee ...	Richard J. Brooks	Newsletter Publisher ..	Charlotte Prater
Vice President	OPEN	Performances Contact ..	Dave Williams
Recording Secretary	Dinah Showman	Publicity	OPEN
Treasurer	Janet Johnston	Webmaster	Pete Showman
Membership Secretary	Pete Showman	Youth Programs Chair	OPEN
News Editor	Patrice Tanti	Youth Fiddle Contest	Pete Showman

Trustees

Seat 1: Pete Showman	Seat 3: George Bradshaw	Seat 5: Dave Williams
Seat 2: Élan Alford	Seat 4: Charlotte Prater	Seat 6: Susan Goodis

To Contact the SCVFA:

Mail: P.O. Box 2666, Cupertino, CA 95015-2666
 Email to Richard Brooks: president at fiddlers.org Phone: (650) 328-3939

Newsletter Submissions & Comments:

Email: newsletter at fiddlers.org

Website: www.scvfa.org or www.fiddlers.org
 Copyright 2015, Santa Clara Valley Fiddlers Association

KAMIMOTO
 STRING INSTRUMENTS

**“Fiddles
 for
 Every Style...”**

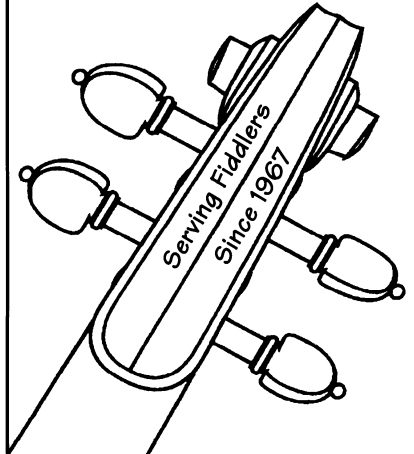

- New & Old Instruments
- Repairs & Restorations
- One-hour bow rehairing (by appt.)
- Rentals: Violin, Viola, Cello, Bass

Hours: Mon-Sat 10:00 - 5:30

[408] 298-8168
www.kamimotostrings.com

609 North Fourth Street
 San Jose, CA 95112

[800] 892-3199

Fax: [408] 298-8198

Snacks for the Jam

On your way to the jam? Please bring a snack to share!



SCVFA Happenings

August Events

(Compliments of Allan French)

- Bluegrass at the Lake (Lodi, CA)
- Bowers Mansion Bluegrass Festival (Reno, NV)
- Dead on the Creek Festival (Willits, CA)
- Golden Old-Time Campout (Lake Sonoma, CA)
- Good Old-Fashioned Bluegrass Festival (Tres Piños, CA)
- Olalla Bluegrass & Beyond Festival (Olalla, WA)
- Summergrass Festival (Vista, CA)

House Concerts at the home of Susan Goodis in Mountain View

For more information and to be added to the Silicon Valley House Concerts Group email list, send your email to Susan at SGoodis [at] gmail.com.

- Sept 24, 2015 Canote Brothers
- Sept 26, 2015 Canote Brothers: Guitar & Fiddle Workshops at Gryphon Music
- Dec 5, 2015 Megan Lynch Chowning: afternoon fiddle workshop & evening house concert

Slow Jam Tunes

Topher Heath writes:

Hello! Thank you all for participating in the slow jam. The slow jam is for beginners who want to participate in a slow-paced jam (60-90 BPM).

To participate, you should be able to tune your instrument, play chords at a steady pace, and (optionally) work up melodies / leads.

The jam was very well attended in June and all the musicians had a good time.

D Arkansas Traveler (Published July 2015)
A Cripple Creek (Included page 6)
G Girl I Left Behind Me (Included page 7)
G Hot Corn, Cold Corn *NEW in June
D Liberty (Included page 7)
G Long Journey Home *NEW in July
G Mountain Dew *NEW in May
A Old Joe Clark
A Red-Haired Boy *NEW in July
D Soldier's Joy
C Wildwood Flower
A Will The Circle Be Unbroken *NEW in May
G Worried Man Blues

Check here first for songs:

<http://www.scvfa.org/tunes/>

If you have trouble finding a song, feel free to send me a note at [topher.heath \[at\] xxxxxxxx](mailto:topher.heath@xxxxxxx).

We will try to include sheet music for tunes used in the slow jam in the Fiddler's Rag over the next few months.

SCVFA Meeting Notes

At its regular meeting on July 19, 2015, trustees

- Learned that a new microphone was purchased to replace the broken one.
- Agreed that Jeanne Sawyer and Anders Holtsberg, who play Scandinavian music, be invited to be featured performers at our October jam.
- Agreed that we not hold a Youth Fiddle Contest this year.
- Agreed to offer a KidFiddle class in the fall or next spring.
- Considered possible designs for use on SCVFA T-shirts and other items.
- Discussed issues and possible changes that could be made to our website to make it more informative and more useable with mobile devices.
- Discussed names and structure of our beginners jams (our newer very slow jam, and our earlier beginners' circle that has become an intermediates' tune-building jam). Agreed that the old beginners' circle be called the Tunebuilder session (or something similar).
- Made plans for an SCVFA payout (performance) at the Saratoga Retirement Community in August.
- Agreed to try to organize a mini-concert at a future jam.
- Agreed to order more SCVFA business cards.
- Agreed to offer short performances to local schools to support Colonial Days lessons/activities.
- Proposed September 13 or 20, 2015, as the next trustee meeting date.

Dinah Showman, Secretary

Lost and Found

Lost at the July jam in the park: a small instrument tuner. Check at the membership table or call Pete, [408.255.0297](tel:408.255.0297)

SCVFA Worldwide

This summer, some SCVFA members wouldn't leave their fiddles behind while on vacation. They also made sure to share their talent at the first opportunity:

- **Ethan** and **Caedmon** in Ireland (Photos next page).
- **Dorian** and **Susan** in Greece (Photo below).

Please send us pics of yourself fiddling, while travelling anywhere in the world!



Dorian Martinka and **Susan Goodis** were island hopping in Greece. Here they are entertaining on a Catamaran in the Mediterranean. Dorian is playing a unique travel violin called wipLstix.
(Photo: Matt Mathis)

Fiddling in Ireland

By *Ethan Dickson*

My brother, Caedmon, and I had an Irish musical adventure in June during our family's visit with friends in County Galway. One evening, our family brought us with our fiddles to a session in Matt Molloy's, a pub owned by the flute/whistle player of The Chieftains. The session leaders gave us a lot of encouragement (and teased us), and then introduced us to Matt Molloy himself. (We didn't know who he was.)

The next day, we went out for a bit of fun onto the streets of Galway to play for passers-by.

To our surprise, we drew a huge crowd on a corner of Quay Street as the people were attracted to our six-song loop: Irish Washerwoman, The Girl I Left Behind Me, Spotted Pony, Boil 'Em Cabbage Down, Sweet Betsy from Pike, and Arkansas Traveler (my solo). We were the only traditional music act on the streets that afternoon, and the many tourists and locals seemed to like it.

"At first I was nervous," said Caedmon, "but as time went by, I felt more and more comfortable." We played almost an hour, and we earned about \$90!



Ethan and Caedmon Dickson entertain passers-by in a Galway street this summer (photos: Todd Dickson)

A simple version of Cripple Creek, more or less as I would sing it:

Key: A major
♩ = 90

Cripple Creek

Traditional old-time
Arr. Pete Showman

The slides are optional

Here are some example lyrics. You can find many more on the Web.

- A. I've got a gal at the head of the creek, goin' up to see her 'bout two times a week.
She's got eyes of darkest brown, makes my head turn all a-roun'
- B. Goin' up Cripple Creek, goin' on a run, goin' up Cripple Creek to have a little fun.
Goin' up Cripple Creek, goin' in a whirl, goin' up Cripple Creek to see my girl.

A fancier version that could be used as a basic bluegrass break:

Key: A major
♩ = 90

Cripple Creek

Traditional
Arr. Pete Showman

Here are the equivalent chords in G, for those who may be using a capo to play in A. There are 2 beats per measure. A slash '/' means to repeat the same chord on the 2nd beat.

[A part] | : G / | C G | G / | D G : |
[B part] | : G / | G / | G / | D G : |

Typeset in ABC by Pete Showman, 7/12/2015 (rev. 2).

The Girl I Left Behind Me

G Maj.
♩ = 100

Traditional, arr. Pete Showman

Arr. by Pete Showman 9/20/2005; re-typeset in ABC 1/31/2014 (r1)

(D.S. to repeat)

Liberty

Key: D Maj.
♩ = 90

Trad., arr. Pete Showman,
more or less as I play it

** I "mix and match" these bowing variations (and probably others) in measures 1, 3 and 5. Measures 9 and 13 also show two variations on the same basic melody. There are lots of ways to play this. I've posted some other variations at www.fiddlers.org/tunes/

Arr. and typeset in ABC by Pete Showman 1/31/2014.

Santa Clara Valley Fiddlers Association
P.O. Box 2666
Cupertino, CA 95015-2666

**Rose Garden Park
July & August
2015**

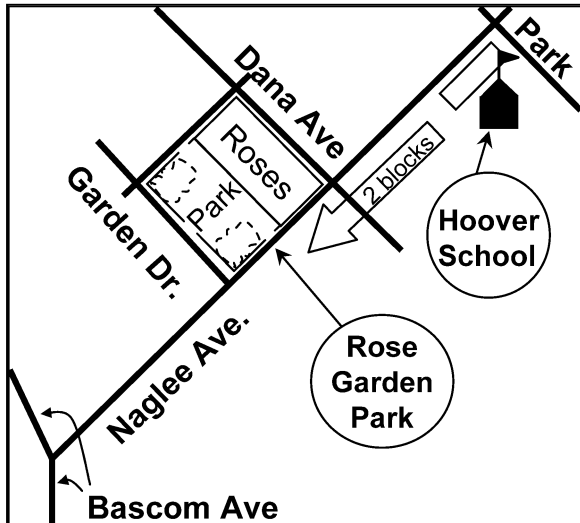

**Next Jam: Sunday Aug. 2 at 1 pm
Rose Garden Park (see map)
Look for us under the trees!**

Damaged or Missing Issue? Call us,
or email to: newsletter [at] scvfa.org

Painting by Marc Chagall. "The Fiddler (Le violoniste)," 1912-1913 (Collection Stedelijk Museum Amsterdam). This masterpiece inspired the title "Fiddler on the Roof".

